

KNOTWOOD, A DIVISION OF OMNIMAX

TEST REPORT

SCOPE OF WORK

PERFORMANCE TESTING ON 2 IN BY 2 IN AND 2 IN BY 4 IN BATTEN SYSTEMS

REPORT NUMBER

J1921.01-119-19 R0

TEST DATE(S)

07/22/19 - 07/29/19

ISSUE DATE

10/08/19

RECORD RETENTION END DATE

07/29/23

PAGES

21

DOCUMENT CONTROL NUMBER

ATI 00704 (07/28/17)

RT-R-AMER-Test-2858

© 2017 INTERTEK

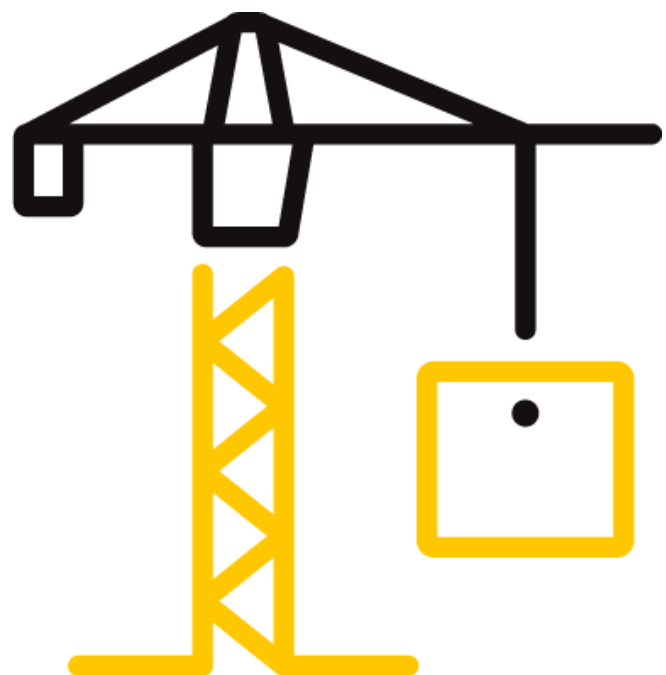

TEST REPORT FOR KNOTWOOD, A DIVISION OF OMNIMAX

Report No.: J1921.01-119-19 R0

Date: 10/08/19

REPORT ISSUED TO

KNOTWOOD, A DIVISION OF OMNIMAX INTERNATIONAL

30 Technology Parkway South

Suite 400 / Suite 600

Peachtree Corners, GA 30092

SECTION 1

SCOPE

Intertek Building & Construction (B&C) was contracted by Knotwood, A Division of Omnimax International, Peachtree Corners, GA, to conduct structural performance testing on their 2 in by 2 in and 2 in by 4 in batten systems. Results obtained are tested values and were secured by using the designated test method. Testing was conducted at the Intertek B&C test facility in York, PA.

Intertek B&C in York, Pennsylvania has demonstrated compliance with ISO/IEC International Standard 17025 and is consequently accredited as a Testing Laboratory (TL-144) by International Accreditation Service, Inc. (IAS).

This report does not constitute certification of this product nor an opinion or endorsement by this laboratory.

For INTERTEK B&C:

COMPLETED BY:	Robert G. Spayd
TITLE:	Technician II
SIGNATURE:	
DATE:	10/08/19

REVIEWED BY:	V. Thomas Mickley, Jr., P.E.
TITLE:	Senior Staff Engineer
SIGNATURE:	
DATE:	10/08/19

RGS:vtm/aas

This report is for the exclusive use of Intertek's Client and is provided pursuant to the agreement between Intertek and its Client. Intertek's responsibility and liability are limited to the terms and conditions of the agreement. Intertek assumes no liability to any party, other than to the Client in accordance with the agreement, for any loss, expense or damage occasioned by the use of this report. Only the Client is authorized to permit copying or distribution of this report and then only in its entirety. Any use of the Intertek name or one of its marks for the sale or advertisement of the tested material, product or service must first be approved in writing by Intertek. The observations and test results in this report are relevant only to the sample(s) tested. This report by itself does not imply that the material, product, or service is or has ever been under an Intertek certification program.

TEST REPORT FOR KNOTWOOD, A DIVISION OF OMNIMAX

Report No.: J1921.01-119-19 R0

Date: 10/08/19

SECTION 2

TEST METHOD(S)

Per the client's request, the specimens were evaluated using the test methods described in the following:

ANSI/SPRI/FM 4435/ ES-1 2017, *Test Standard for Edge Systems Used with Low Slope Roofing Systems*

SECTION 3

MATERIAL SOURCE/INSTALLATION

Test samples were provided by the client. Representative samples of the test specimen(s) will be retained by Intertek B&C for a minimum of four years from the test completion date.

The batten systems included a "base" and "cap" section which snapped together. When a batten system was used as a midspan support (intermediate column), its base section was rigidly attached to a stanchion prior to snapping on the cap section.

The batten systems tested as a single span condition were attached at each end to a 1/4 in thick steel section using two, #10 by 1-7/16" tek screws at each support. The center-to-center distance of the attachment locations was 13 ft - 0 in.

The batten systems tested as a two-span condition were attached at each end to a 1/4 in thick steel section and at the midpoint to the cap section of a 2 in by 2 in batten used as an intermediate column using two, #10 by 1-7/16" tek screws at each support. The center-to-center distance of the attachment locations was 7 ft - 0 in.

The supports were rigidly attached to the test frame and were included in the test specimen only to facilitate anchorage of the batten system and were not a tested component. The structural capacity of the supports was not included in the scope of this testing and would need to be evaluated separately.

SECTION 4

LIST OF OFFICIAL OBSERVERS

NAME	COMPANY
Adam J. Schrum	Intertek B&C
V. Thomas Mickley, Jr., P.E.	Intertek B&C

TEST REPORT FOR KNOTWOOD, A DIVISION OF OMNIMAX

Report No.: J1921.01-119-19 R0

Date: 10/08/19

SECTION 5

TEST PROCEDURE

All testing reported herein was conducted in a laboratory set to maintain temperature in the range of 68 ± 4°F and humidity in the range of 50 ± 5% RH.

The base section of each batten system was attached to the supports. The cap section was then snapped onto the base and equal length chains, located 6 in from each support and 12 in on-center, were wrapped around the batten system and the load distribution beam. Load was applied to the load distribution beam via a steel cable and an electric winch. Load was applied in both the directions, towards support and away from support, to simulate the effects of wind loads in any direction. Applied load was measured with an in-line 2000 pound load cell. Center-point deflection of the batten was measured with an electronic linear displacement transducer. Load was applied incrementally and held ("sustained") for a minimum of 60 seconds with intermediate load relaxation periods for specimen deflection to stabilize. See Photographs in Section 8 and Drawings in Section 9 for additional details.

SECTION 6

TEST SPECIMEN DESCRIPTION

PRODUCTS	Base	2 in cap	4 in cap
PART NUMBERS	KEB5050M	KEB5050F	KEB10050M
MANUFACTURER	OmniMax International		
MATERIAL	6063-T6 extruded aluminum		
WIDTH	1-7/8 in	1-27/32 in	3-13/16 in
HEIGHT	2 in	2 in	2 in
WALL THICKNESS	0.075 in / 0.080 in	0.058 in / 0.123 in	0.070 in / 0.090 in
SPAN/SPECIMEN LENGTH	- Single span 13 ft center-of-support to center-of-support / 14 ft specimen length - Two-span 7 ft center-of-support to center-of-support / 15 ft specimen length		
FASTENERS	- Base Section to Support: Two, #10-24 by 1-7/16" Philips drive, trim head, self-drilling tek screws - Base Section to Cap Section: Snap fit - No mechanical connection		

TEST REPORT FOR KNOTWOOD, A DIVISION OF OMNIMAX

Report No.: J1921.01-119-19 R0

Date: 10/08/19

SECTION 7

TEST RESULTS

Product: 2 in by 4 in Batten

Span: 13 ft - 0 in (Single Span)

Direction of Load: Towards Support

Test Dates: 07/24/19 and 07/25/19

SURFACE LOAD (lb/ft ²)	TARGET LOAD (lbf)	TEST NO. 1		TEST NO. 2		TEST NO. 3		AVERAGE	
		LOAD (lbf)	DEFLECTION (in)	LOAD (lbf)	DEFLECTION (in)	LOAD (lbf)	DEFLECTION (in)	LOAD (lbf)	DEFLECTION (in)
25	54	59	0.099	58	0.067	57	0.097	58	0.088
50	108	120	0.143	117	0.145	115	0.202	117	0.163
75	163	174	0.213	179	0.227	171	0.273	175	0.238
100	217	225	0.273	227	0.270	229	0.340	227	0.294
125	271	281	0.359	280	0.312	289	0.402	283	0.358
150	325	335	0.396	333	0.365	338	0.448	335	0.403
160	347	358	0.422	355	0.378	357	0.471	357	0.424
170	368	379	0.443	379	0.400	380	0.490	379	0.444
180	390	403	0.468	407	0.429	401	0.512	404	0.470
190	412	425	0.491	421	0.452	422	0.531	423	0.491
200	433	445	0.519	441	0.472	451	0.563	446	0.518
210	455	468	0.546	467	0.493	470	0.573	468	0.537
220	477	487	0.568	489	0.515	486	0.595	487	0.559
230	498	506	0.594	506	0.537	510	0.615	507	0.582
240	520	529	0.623	531	0.553	529	0.637	530	0.604
250	542	554	0.654	551	0.577	553	0.658	553	0.630
260	563	572	0.673	575	0.602	573	0.679	573	0.651
270	585	600	0.707	595	0.625	599	0.704	598	0.679
280	607	627	0.739	618	0.661	619	0.725	621	0.708
290	628	641	0.759	644	0.689	646	0.753	644	0.734
300	650	666	0.792	663	0.705	669	0.774	666	0.757

TEST REPORT FOR KNOTWOOD, A DIVISION OF OMNIMAX

Report No.: J1921.01-119-19 R0

Date: 10/08/19

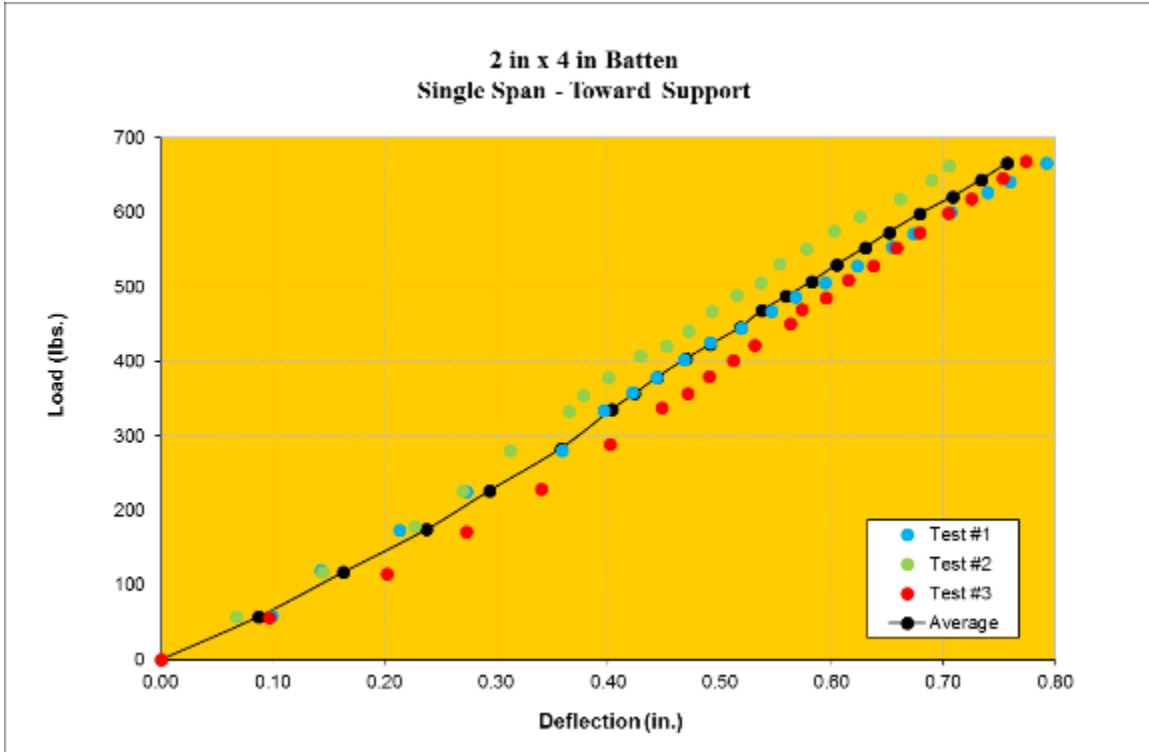

TEST REPORT FOR KNOTWOOD, A DIVISION OF OMNIMAX

Report No.: J1921.01-119-19 R0

Date: 10/08/19

Product: 2 in by 4 in Batten

Span: 13 ft - 0 in (Single Span)

Direction of Load: Away from Support

Test Dates: 07/22/19 - 07/24/19

SURFACE LOAD (lb/ft ²)	TARGET LOAD (lbf)	TEST NO. 1		TEST NO. 2		TEST NO. 3		AVERAGE	
		LOAD (lbf)	DEFLECTION (in)	LOAD (lbf)	DEFLECTION (in)	LOAD (lbf)	DEFLECTION (in)	LOAD (lbf)	DEFLECTION (in)
25	54	--	--	57	0.033	56	0.031	57	0.032
50	108	115	0.123	112	0.114	116	0.137	114	0.125
75	163	--	--	166	0.215	172	0.222	169	0.219
100	217	228	0.285	222	0.277	226	0.303	225	0.288
125	271	--	--	278	0.331	317	0.339	298	0.335
150	325	330	0.426	341	0.371	338	0.371	336	0.389
160	347	351	0.455	368	0.383	355	0.453	358	0.430
170	368	376	0.489	374	0.383	380	0.479	377	0.450
180	390	394	0.514	399	0.394	398	0.499	397	0.469
190	412	425	0.552	419	0.400	419	0.518	421	0.490
200	433	437	0.573	440	0.414	450	0.550	442	0.512
210	455	460	0.614	461	0.426	463	0.563	461	0.534
220	477	486	0.654	482	0.436	484	0.587	484	0.559
230	498	503	1.059 ¹	504	0.449	510	0.612	506	0.707
240	520	527	1.090	534	0.477	533	0.657	531	0.741
250	542	551	1.099	551	0.485	551	0.676	551	0.753
260	563	571	1.111	578	0.500	579	0.695	576	0.769
270	585	594	1.125	598	0.506	601	0.706	598	0.779
280	607	615	1.143	634	0.521	617	0.718	622	0.794
290	628	641	1.161	648	0.526	646	0.737	645	0.808
300	650	661	1.175	669	0.533	674	0.753	668	0.820

¹ Cap section began to separate from base section however, the specimen was still able to hold the test load.

TEST REPORT FOR KNOTWOOD, A DIVISION OF OMNIMAX

Report No.: J1921.01-119-19 R0

Date: 10/08/19

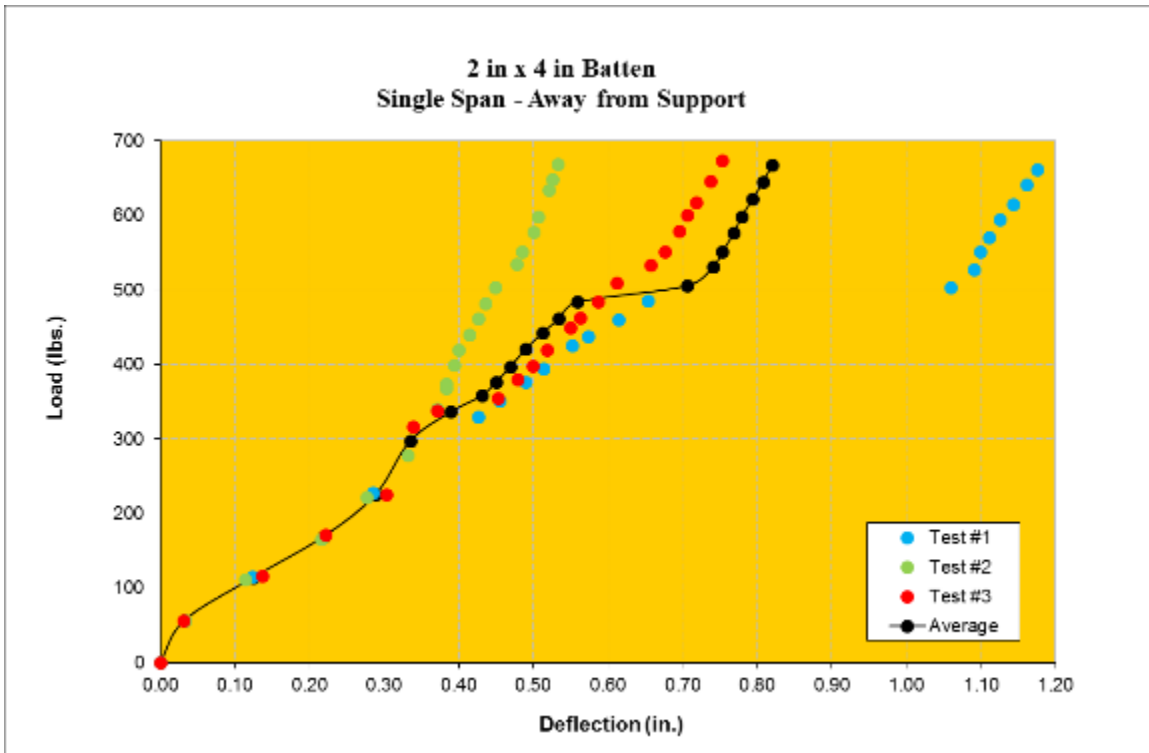

TEST REPORT FOR KNOTWOOD, A DIVISION OF OMNIMAX

Report No.: J1921.01-119-19 R0

Date: 10/08/19

Product: 2 in by 2 in Batten

Span: 7 ft - 0 in (Two-Span)

Direction of Load: Towards Support

Test Dates: 07/25/19 and 07/26/19

SURFACE LOAD (lb/ft ²)	TARGET LOAD (lbf)	TEST NO. 1		TEST NO. 2		TEST NO. 3		AVERAGE	
		LOAD (lbf)	DEFLECTION (in)	LOAD (lbf)	DEFLECTION (in)	LOAD (lbf)	DEFLECTION (in)	LOAD (lbf)	DEFLECTION (in)
25	58	62	0.011	63	0.005	65	0.004	63	0.006
50	117	160	0.039	121	0.013	123	0.009	135	0.020
75	175	186	0.046	185	0.043	184	0.017	185	0.035
100	233	241	0.081	245	0.100	240	0.034	242	0.071
125	292	302	0.122	305	0.143	302	0.061	303	0.108
150	350	362	0.153	360	0.178	364	0.092	362	0.141
160	373	380	0.161	385	0.192	383	0.101	383	0.151
170	397	406	0.174	405	0.206	411	0.116	407	0.165
180	420	432	0.186	431	0.222	435	0.131	433	0.179
190	443	459	0.198	454	0.236	460	0.143	458	0.192
200	467	481	0.208	480	0.251	477	0.149	479	0.202
210	490	502	0.217	507	0.265	500	0.162	503	0.214
220	513	533	0.228	527	0.277	534	0.191	531	0.232
230	537	549	0.237	546	0.287	552	0.210	549	0.244
240	560	567	0.245	577	0.303	575	0.215	573	0.254
250	583	594	0.252	595	0.312	600	0.223	596	0.262
260	607	648	0.275	617	0.323	626	0.232	630	0.277
270	630	651	0.276	646	0.336	651	0.243	649	0.285
280	653	666	0.284	670	0.349	671	0.249	669	0.294
290	677	695	0.296	689	0.358	695	0.258	693	0.304
300	700	720	0.305	716	0.369	722	0.269	719	0.314

Note: Reported deflections are the average of the midspan deflections from spans 1 and 2.

TEST REPORT FOR KNOTWOOD, A DIVISION OF OMNIMAX

Report No.: J1921.01-119-19 R0

Date: 10/08/19

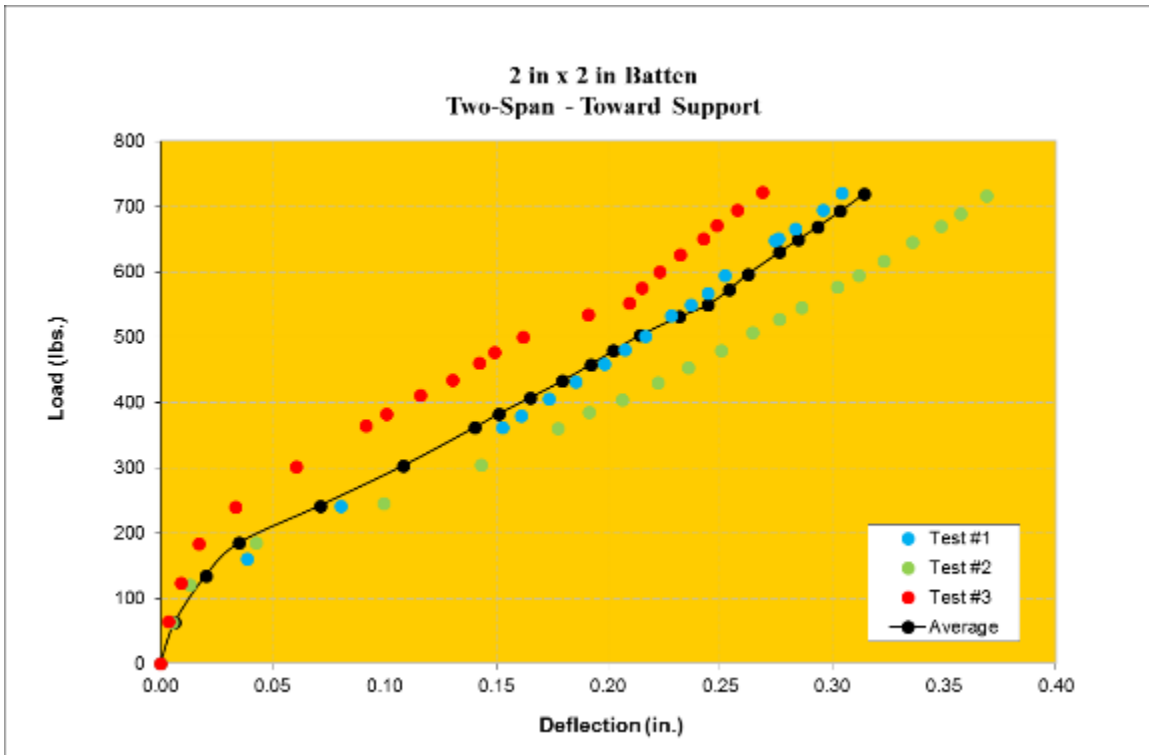

TEST REPORT FOR KNOTWOOD, A DIVISION OF OMNIMAX

Report No.: J1921.01-119-19 R0

Date: 10/08/19

Product: 2 in by 2 in Batten

Span: 7 ft - 0 in (Two-Span)

Direction of Load: Away from Support

Test Date: 07/26/19 and 07/29/19

SURFACE LOAD (lb/ft ²)	TARGET LOAD (lbf)	TEST NO. 1		TEST NO. 2		TEST NO. 3		AVERAGE	
		LOAD (lbf)	DEFLECTION (in)	LOAD (lbf)	DEFLECTION (in)	LOAD (lbf)	DEFLECTION (in)	LOAD (lbf)	DEFLECTION (in)
25	58	63	0.036	62	0.039	61	0.047	62	0.041
50	117	124	0.197	131	0.124	124	0.170	126	0.163
75	175	184	0.254	188	0.175	190	0.234	187	0.221
100	233	244	0.317	245	0.212	244	0.283	244	0.271
125	292	303	0.372	304	0.248	302	0.332	303	0.317
150	350	360	0.417	366	0.295	355	0.374	360	0.362
160	373	383	0.440	383	0.306	378	0.372	381	0.372
170	397	408	0.456	406	0.325	406	0.383	407	0.388
180	420	431	0.472	426	0.334	429	0.394	429	0.400
190	443	457	0.497	450	0.343	453	0.409	453	0.416
200	467	478	0.513	471	0.357	478	0.430	476	0.433
210	490	501	0.528	494	0.396	502	0.434	499	0.452
220	513	525	0.549	521	0.386	526	0.444	524	0.459
230	537	563	0.580	549	0.380	551	0.456	554	0.472
240	560	577	0.591	572	0.387	573	0.466	574	0.481
250	583	608	0.610	596	0.401	593	0.475	599	0.495
260	607	625	0.622	617	0.400	628	0.490	623	0.504
270	630	647	0.637	648	0.450	639	0.500	645	0.529
280	653	681	0.659	666	0.472	674	0.515	674	0.549
290	677	701	0.671	681	0.516	687	0.524	690	0.570
300	700	722	0.682	733	0.519	709	0.535	721	0.579

Note: Reported deflections are the average of the midspan deflections from spans 1 and 2.

TEST REPORT FOR KNOTWOOD, A DIVISION OF OMNIMAX

Report No.: J1921.01-119-19 R0

Date: 10/08/19

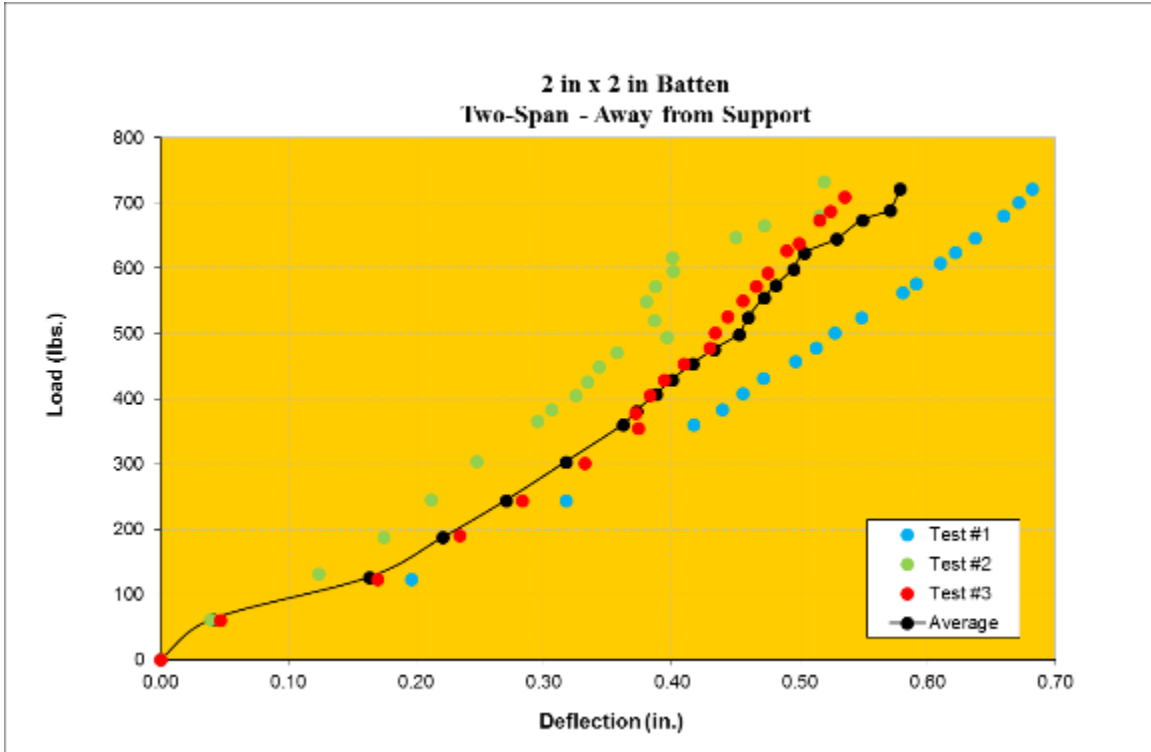

TEST REPORT FOR KNOTWOOD, A DIVISION OF OMNIMAX

Report No.: J1921.01-119-19 R0

Date: 10/08/19

SECTION 8 PHOTOGRAPHS



Photo No. 1

2 in by 4 in Batten, Single Span, Load Away from Support - Test Setup



Photo No. 2

2 in by 4 in Batten, Single Span, Load Towards Support - Test Setup

TEST REPORT FOR KNOTWOOD, A DIVISION OF OMNIMAX

Report No.: J1921.01-119-19 R0

Date: 10/08/19



Photo No. 3

2 in by 2 in Batten, Two-Span, Load Away from Support - Test Setup



Photo No. 4

2 in by 2 in Batten, Two-Span, Load Towards Support - Test Setup

TEST REPORT FOR KNOTWOOD, A DIVISION OF OMNIMAX

Report No.: J1921.01-119-19 R0

Date: 10/08/19



Photo No. 5

Typical Base Section to Intermediate Support Connection (Two-Span Test Setup)



Photo No. 6

Typical Base Section to Support Connection (Single and Two-Span Test Setup)

TEST REPORT FOR KNOTWOOD, A DIVISION OF OMNIMAX

Report No.: J1921.01-119-19 R0

Date: 10/08/19

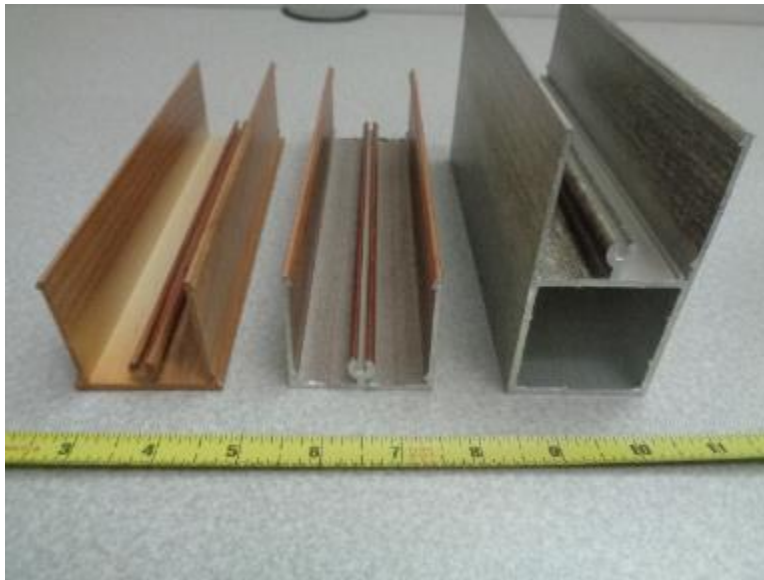

Photo No. 7

Batten Components (from Left to Right); Base Section, 2 in Cap Section, 4 in Cap Section



Photo No. 8

Typical Batten to Support Fastener



Total Quality. Assured.

130 Derry Court
York, Pennsylvania 17406

Telephone: 717-764-7700
Facsimile: 717-764-4129
www.intertek.com/building

TEST REPORT FOR KNOTWOOD, A DIVISION OF OMNIMAX

Report No.: J1921.01-119-19 R0

Date: 10/08/19

SECTION 9 DRAWINGS

The "As-Built" drawings for the 2 in by 2 in and 2 in by 4 in batten systems which follow have been reviewed by Intertek B&C and are representative of the project reported herein. Project construction was verified by Intertek B&C per the drawings included in this report. Any deviations are documented herein or on the drawings.

CUSTOMER APPROVAL DRAWING

EXCLUSIVE SHAPES - WHERE THE SHAPE IS DEVELOPED AS AN "EXCLUSIVE", THE CUSTOMER WHOSE NAME APPEARS ON THIS DRAWING SHALL ACCEPT FULL RESPONSIBILITY FOR ALL CLAIMS MADE AGAINST THE CUSTOMER, PERSONS CLAIMING UNDER THE CUSTOMER, OR CAPRAL LIMITED, IF THE EXTRUDED SHAPE SHOWN AND PRODUCTS MADE FROM IT INFRINGES ANY INTELLECTUAL PROPERTY RIGHT, INCLUDING PATENT, DESIGN OR COPYRIGHT, OR IS THE SUBJECT OF CONFIDENTIAL INFORMATION AND THE CUSTOMER SHALL INDEMNIFY CAPRAL LIMITED AGAINST ALL DAMAGES, LOSSES AND EXPENSES ARISING OUT OF ANY CLAIM.

SHAPE DIMENSIONS - THIS DRAWING HAS BEEN CHECKED FOR CORRECT DIMENSIONS, TOLERANCES AND ANY OTHER SPECIAL WRITTEN REQUIREMENTS BY THE CUSTOMER. ALTERATIONS MADE AFTER TOOLAGE MANUFACTURE IS COMMENCED WILL BE AT THE CUSTOMER'S ACCOUNT

CUSTOMER _____ DATE _____
SIGNATURE _____

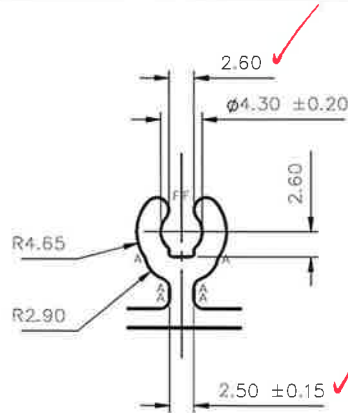

intertek

Test sample complies with these details.
Deviations are noted.

Report # V1921.01

Date 9/10/19 Tech RGS

CAPRAL ALUMINIUM

© CAPRAL LIMITED 2014 ACN 78 004 213 852

FIGURE NO. 33079 SECTION NO. TS51717/F

HANDLING

NOT APPLICABLE

WRAPPING

NOT APPLICABLE

PACKING

NOT APPLICABLE

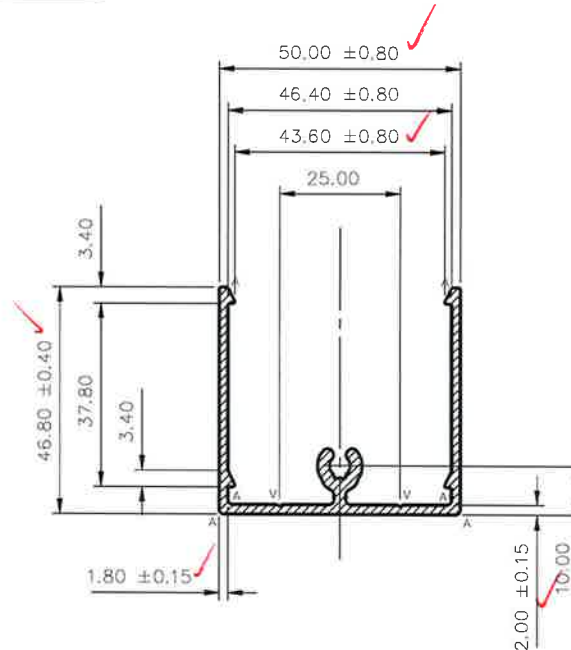
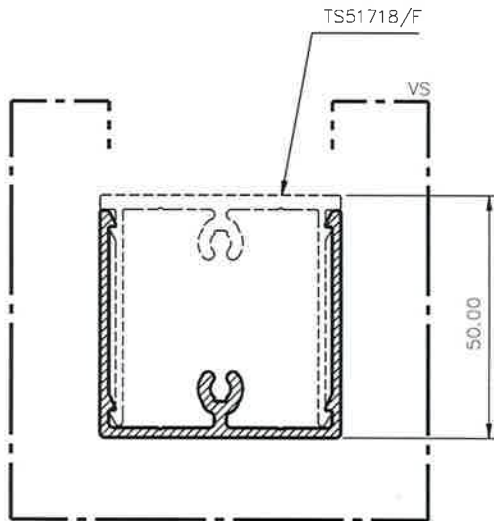

A = 1.00 R
F = FULL R
V = STD VEE GROOVES

1 2 3 4 5 6 7 8 9 10 11 12 13 14 15 16 17 18 19 20 21 22 23 24 25 26

STRAIGHTNESS mm	2.00 X 200mm	GENERAL
FLATNESS mm	0.10mm/25mm	ALL CORNERS 0.40mm RADIUS UNLESS OTHERWISE SPECIFIED
WARP mm	1.20 X TOTAL LENGTH	3° MAX
ANGULARITY	± 2°	
SPECIAL TOLERANCES:	STD 10 3/4 n 1/4 TO 1/2 n 1/2 TO 1/4 n	LESS THAN 1/4 n
PRESS	1 2 3 4 5 6 7 8 9 10 11 12 13 14 15 16 17 18 19 20 21 22 23 24 25 26	
SAW	1 2 3 4 5 6 7 8 9 10 11 12 13 14 15 16 17 18 19 20 21 22 23 24 25 26	
PACKING		

ORDER NO.	6063	ALU REF. NO.	T6	FINISH	ARCH	CUSTOMER	KNOTWOOD PTY LTD	ACCOUNT NO.	121262
TOTAL PER METER	328	ANOD REF. NO.	328	PART REF. NO.	219	SHAPE ORIGIN	KNOTWOOD PTY LTD.	ISSUE	FE 18.09.2014
ANOD mm	326	MASS kg/m	0.880	FACTORY	373	CUSTOMER PART NO.	50mm BATTEN	END USE	AK 18.09.2014
COLOUR	68	DATE	S	COMPLETION	M	APPLICATION	PATIOS/CARPORTS	APPROVED	ER 18.09.2014

FIGURE NO. 33079 SECTION NO. TS51717/F

CUSTOMER APPROVAL DRAWING

EXCLUSIVE SHAPES - WHERE THE SHAPE IS DEVELOPED AS AN "EXCLUSIVE" THE CUSTOMER WHOSE NAME APPEARS ON THIS DRAWING SHALL ACCEPT FULL RESPONSIBILITY FOR ALL CLAIMS MADE AGAINST THE CUSTOMER, PERSONS CLAIMING UNDER THE CUSTOMER, OR CAPRAL LIMITED, IF THE EXTRUDED SHAPE SHOWN AND PRODUCTS MADE FROM IT INFRINGES ANY INTELLECTUAL PROPERTY RIGHT, INCLUDING PATENT, DESIGN OR COPYRIGHT, OR IS THE SUBJECT OF CONFIDENTIAL INFORMATION AND THE CUSTOMER SHALL INDEMNIFY CAPRAL LIMITED AGAINST ALL DAMAGES, LOSSES AND EXPENSES ARISING OUT OF ANY CLAIM.

SHAPE DIMENSIONS - THIS DRAWING HAS BEEN CHECKED FOR CORRECT DIMENSIONS, TOLERANCES AND ANY OTHER SPECIAL WRITTEN REQUIREMENTS BY THE CUSTOMER. ALTERATIONS MADE AFTER TOOLAGE MANUFACTURE IS COMMENCED WILL BE AT THE CUSTOMER'S ACCOUNT.

CUSTOMER _____ DATE _____
SIGNATURE _____

intertek

Test sample complies with these details.

Deviations are noted.

Report # J1921.01

Date 9/10/19 Tech RG5

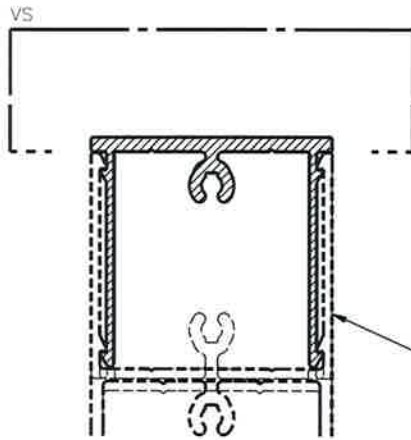
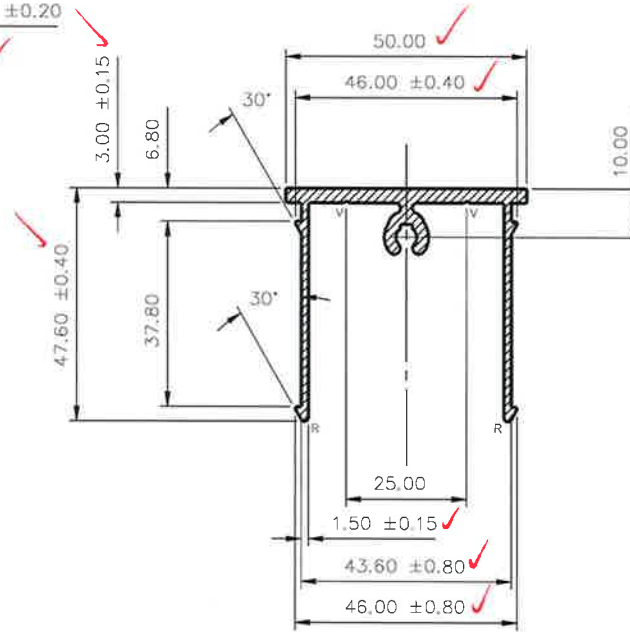
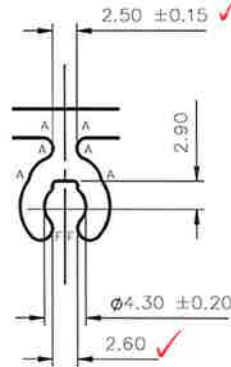

TS51714/G
TS51415/G
TS51416/G
TS51717/F

A = 1.00 R
F = FULL R
R = R TO SUIT
V = STD VEE GROOVES

CAPRAL
ALUMINIUM

© CAPRAL LIMITED 2014 ACN 78 004 213 651

LIC No. _____ TRADE _____

ISSUE NO 33080 SECTION NO TS51718/F

HANDLING

NOT APPLICABLE

WRAPPING

NOT APPLICABLE

PACKING

NOT APPLICABLE

1 2 3 4 5 6 7 8 9 10 11 12 13 14 15 16 17 18 19 20 21 22 23 24 25 26

STRAIGHTNESS mm	2.00 % RMA/PERSONAL TOLERANCES	ALL CORNERS 0.40mm RADIUS UNLESS OTHERWISE SPECIFIED
FLATNESS mm	0.10mm/25mm	
TWIST	1.70 X TOTAL LENGTH, 5° MAX	
ANGULARITY	± 2°	
SPECIAL TOLERANCES	STD TO 3/4 0 1/4 TO 1/2 1/2 TO 1/4 LESS THAN 1/4 0	
PRESS	1 2 3 4 5 6 7 8 9 10 11 12 13 14 15 16 17 18 19 20 21 22 23 24 25 26	
SAW	1 2 3 4 5 6 7 8 9 10 11 12 13 14 15 16 17 18 19 20 21 22 23 24 25 26	
PACKING		

MAKER AS/NZS	6063 T6	FINISH	ARCH	CUSTOMER	KNOTWOOD PTY LTD	ACCOUNT NO	121262	
TOTAL PER METRE	326	PAINT PER METRE	326	FRONT PER METRE	218	SHAPE OWNER	KNOTWOOD PTY LTD	
ANGLE mm	342	FACTOR	0.924	353	CUSTOMER PART NO	BATTEN INFILL	END USE	123
CO mm	67	TEMPERATURE	S	COMPLEXY	M	PATIOS/CARPORTS	APPROVED	FR 18.09.2014
ISSUE NO	33080	SECTION NO	TS51718/F	DATE	18.09.2014	CHECKED	AK	

CUSTOMER APPROVAL DRAWING

EXCLUSIVE SHAPES - WHERE THE SHAPE IS DEVELOPED AS AN "EXCLUSIVE", THE CUSTOMER WHOSE NAME APPEARS ON THIS DRAWING SHALL ACCEPT FULL RESPONSIBILITY FOR ALL CLAIMS MADE AGAINST THE CUSTOMER, PERSONS CLAIMING UNDER THE CUSTOMER, OR CAPRAL LIMITED, IF THE EXTRUDED SHAPE SHOWN AND PRODUCTS MADE FROM IT INFRINGES ANY INTELLECTUAL PROPERTY RIGHT, INCLUDING PATENT, COPYRIGHT, OR IS THE SUBJECT OF CONFIDENTIAL INFORMATION AND THE CUSTOMER SHALL INDEMNIFY CAPRAL LIMITED AGAINST ALL DAMAGES, LOSSES AND EXPENSES ARISING OUT OF ANY CLAIM.

SHAPE DIMENSIONS - THIS DRAWING HAS BEEN CHECKED FOR CORRECT DIMENSIONS, TOLERANCES AND ANY OTHER SPECIAL WRITTEN REQUIREMENTS BY THE CUSTOMER. ALTERATIONS MADE AFTER TOOLING MANUFACTURE IS COMMENCED WILL BE AT THE CUSTOMER'S ACCOUNT.

CUSTOMER _____
SIGNATURE _____ DATE _____

intertek

Test sample complies with these details.
Deviations are noted.

Report # J1921.01
Date 9/10/19 Tech RGS

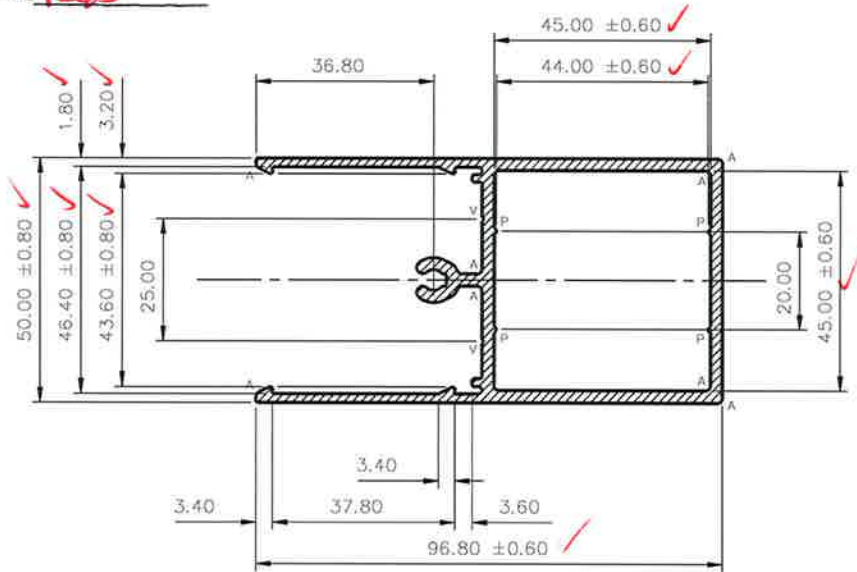
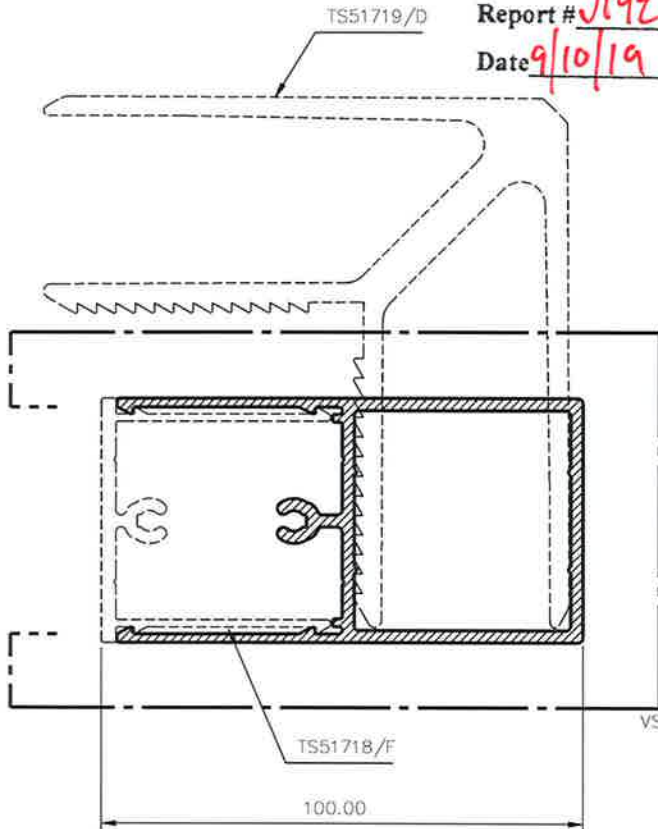
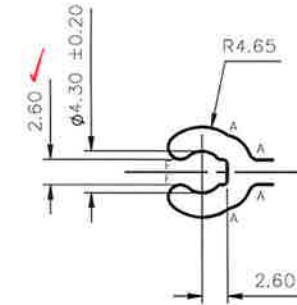
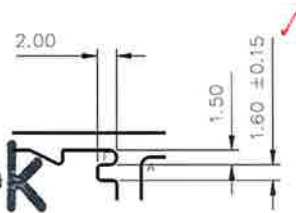

A = 1.00 R
F = FULL R
P = 0.50 x 90° VEE PIPS
V = STD VEE GROOVES

UNSPECIFIED WALL THICKNESS 2.50 ± 0.25

CAPRAL ALUMINIUM

© CAPRAL LIMITED 2014 AEN 18 004 213 617

QUANTITY NO. 33077 SECTION NO. TS51715/G
HANDLING

NOT APPLICABLE

WRAPPING

NOT APPLICABLE

PACKING

NOT APPLICABLE

QUANTITY NO. 33077 SECTION NO. TS51715/G

1 2 3 4 5 6 7 8 9 10 11 12 13 14 15 16 17 18 19 20 21 22 23 24 25 26

STRAIGHTNESS mm	2.00 X 1000	UNSPECIFIED	TOLERANCES WHERE NOT SHOWN WILL BE IN ACCORDANCE WITH AS 1370	6063	T6	ARCH	CUSTOMER	ACCOUNT NO.
FLATNESS mm	0.15mm/25mm		ALL CORNERS 0.40mm RADIUS UNLESS OTHERWISE SPECIFIED	623	443	296	KNOTWOOD PTY LTD	121262
TWIST	0.03 X TOTAL LENGTH 3' MAX			AREA mm	722	1950	KNOTWOOD PTY LTD	DATE ORDER
ANGULARITY	± 0.2°			SALES kg m	319	100mm BATTEN	CUSTOMER PART NO.	DRN NO.
SPECIAL TOLERANCES	STD TO 3/4 P 3/4 TO 1/2 0 7/2 TO 1/4 0 LESS THAN 1/4 0			CO2 mm	109	B	100mm BATTEN	123
PRESS	1 2 3 4 5 6 7 8 9 10 11 12 13 14 15 16 17 18 19 20 21 22 23 24 25 26			CLASS	B	COMPLETION	APPLICATION	DATE
SAW	1 2 3 4 5 6 7 8 9 10 11 12 13 14 15 16 17 18 19 20 21 22 23 24 25 26			CLASS	B	C	PATIOS/CARPORTS	18.09.2014
DRN DATE				ISSUE			APPROVAL	ER 18.09.2014



Total Quality. Assured.

130 Derry Court
York, Pennsylvania 17406

Telephone: 717-764-7700
Facsimile: 717-764-4129
www.intertek.com/building

TEST REPORT FOR KNOTWOOD, A DIVISION OF OMNIMAX

Report No.: J1921.01-119-19 R0

Date: 10/08/19

SECTION 10

REVISION LOG

REVISION #	DATE	PAGES	REVISION
0	10/08/19	N/A	Original Report Issue