

Fire performance of various Knotwood aluminium wall cladding and decking products with respect to the BAL construction requirements of AS 3959-2018

Advisory Report

Author: Heherson Alarde
Report Number: FCO-3525
Quote Number: CO 5621
Date: 16th February 2024
Client: Knotwood Pty Ltd

Commercial-in-confidence

Enquiries should be addressed to:

Fire Testing and Assessments	Author	The Client
NATA Registered Laboratory	Infrastructure Technologies	Knotwood Pty Ltd
14 Julius Avenue	14 Julius Avenue	7/63 Burnside Road
North Ryde, NSW 2113	North Ryde, NSW 2113	Stapylton QLD 4207
Australia	Australia	Australia
	Telephone +61 2 9325 3033	Telephone +61 7 3382 6000

Report Details

Report CSIRO Reference number: FCO-3525/CO5621

Report Status and Revision History

VERSION	STATUS	DATE	DISTRIBUTION	ISSUE NUMBER
Initial Issue	Final	16/2/2024	CSIRO/Client	FCO-3525

Test Report Authorisation

AUTHOR	REVIEWED BY	AUTHORISED BY
Heherson Alarde	Jing Xu	Keith Nicholls
		
16/2/2024	16/2/2024	16/2/2024

Copyright and Disclaimer

© 2024 CSIRO To the extent permitted by law, all rights are reserved and no part of this publication covered by copyright may be reproduced or copied in any form or by any means except with the written permission of CSIRO.

Important disclaimer

CSIRO advises that the information contained in this publication comprises general statements based on scientific research. The reader is advised and needs to be aware that such information may be incomplete or unable to be used in any specific situation. No reliance or actions must, therefore, be made on that information without seeking prior expert professional, scientific and technical advice. To the extent permitted by law, CSIRO (including its employees and consultants) excludes all liability to any person for any consequences, including but not limited to all losses, damages, costs, expenses and any other compensation, arising directly or indirectly from using this publication (in part or in whole) and any information or material contained in it.

Contents

1	Introduction.....	4
2	Referenced Standards	4
3	Description of proposed system.....	5
3.1	Knotwood wall cladding and decking products	5
4	Relevant requirements and evidence.....	11
4.1	AS 3959: 2018 “Non-combustible” definition.....	11
4.2	AS 3959: 2018 “Decking” definition	11
4.3	NCC 2019 Vol 1 C1.9 [NCC 2022 Vol 1 C2D10]	11
4.4	NCC 2019 Vol 2 Part 3.7.1 [NCC 2022 Vol 2 H3D2]	11
4.5	NCC 2019 Vol 1 A5.5 [NCC 2022 Vol 1 A5G6].....	12
4.6	NCC 2019 Vol 1 Schedule 3 Definitions [NCC 2022 Vol 1 Definitions]	12
4.7	NCC 2019 Vol 1 Schedule 6 [NCC 2022 Vol 1 Specification 3].....	12
4.8	AS/NZS 1530.3-1999 Performance.....	13
4.10	Relevance of the requirements of NCC 2019 Vol 1 Schedule 6 [NCC 2022 Vol 1 Specification 3] and AS 3959: 2018 to the proposed construction	15
5	Conclusion	17
6	Term of validity.....	18
7	Limitations	18
Appendix A	Supporting Test Data	19

1 Introduction

This Advisory report outlines the fire performance of various Knotwood aluminium wall cladding and decking products with respect to the BAL construction requirements of AS 3959-2018.

The report is prepared for the purpose of demonstrating compliance with AS 3959-2018 Amdt 1 or 1 & 2 as appropriate for external walls and decking at the appropriate BAL. The report is prepared to meet the requirements of NCC 2019 Volume 1 Amdt 1 & Volume 2 Amdt 1 Clause A5.2 (1) (d) and NCC 2022 Vols 1 & 2 Clause A5G3 (1) (d).

2 Referenced Standards

The proposed system in this report is compared with the construction requirements of:

AS 3959: 2018 Amdt 1	Construction of buildings in bushfire-prone areas. (As referenced in NCC 2019)
AS 3959: 2018 (Amendments 1 & 2)	Construction of buildings in bushfire-prone areas. (As referenced in NCC 2022)

3 Description of proposed system

3.1 Knotwood wall cladding and decking products

The range of Knotwood wall cladding and decking products and components considered in this report are listed in Table 1 and Figures 1-20 below.

Table 1 – Knotwood wall cladding and decking products and components

Product	Alloy Grade	Finish	Colour range
<p>Wall cladding Traditional and Dimensional cladding boards including components (Figures 3 – 11):</p> <ul style="list-style-type: none"> • Clip Ins • Clips • Starters • Corner Trims • Joiner Trims • End Trims • Window Flashing 	6060 Aluminium	Solid colour	Black Monument Woodland Gray Jasper Dune Silver Ironstone Deep Ocean White
		Sublimated Timber Grain	Black Cedar Norwegian Beech Royal Oak Grey Ash White Ash English Chestnut French Walnut Nordic Oak Bush Cherry Teak Brown Spruce Western Red Cedar Queensland Walnut Iroko Merbau Pacific Teak Light Oak Kwila Red Wood Blackbutt Black Wenge Sycamore Spotted Gum Driftwood Silver Wattle Chestnut Aspen
Slip-resistant Timber Grain		Charcoal Canyon Grey Burnt Sienna Smoke Ecru	
<p>Decking Interlocking and T-clip decking boards including components (Figures 14 – 20):</p> <ul style="list-style-type: none"> • Starters • T-Joiners • Joiner Trims • End Trims • Finishing Pieces 			

TOP VIEW

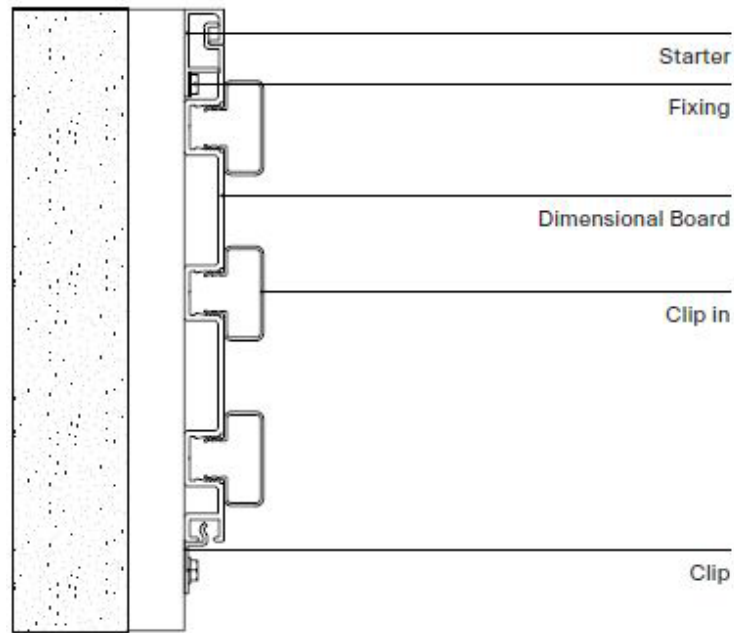

Figure 1 – Typical installation of Dimensional board cladding

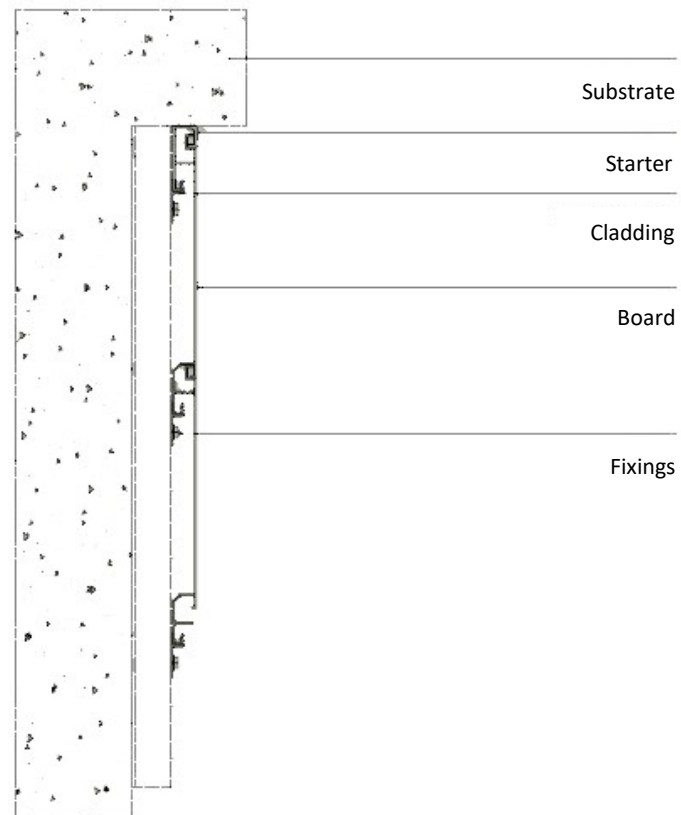
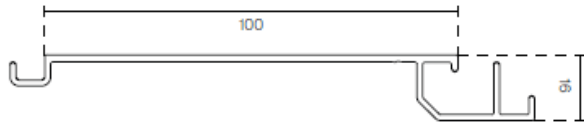
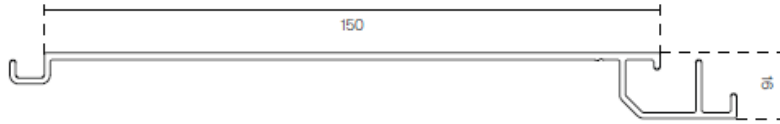

Figure 2 – Typical installation of Traditional board



KEC100LW



KEC150LW

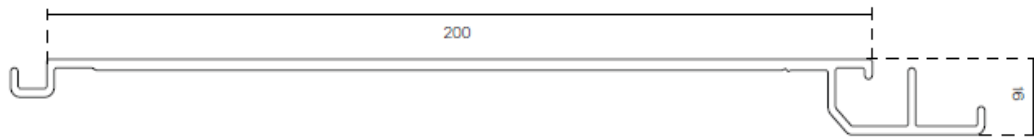

KEC200LW

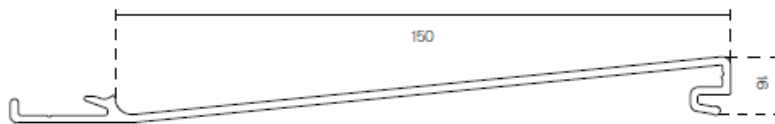

KECSHIP150

Figure 3 – Traditional Boards cladding profiles

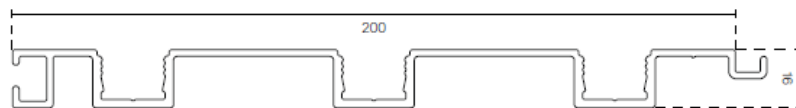

KECDIM200

Figure 4 – Dimensional Board cladding profile

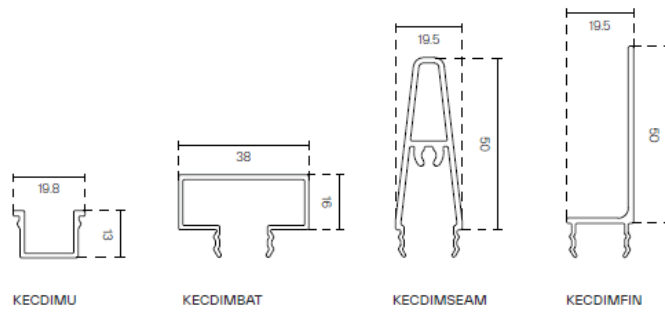

Figure 5 – Clip Ins

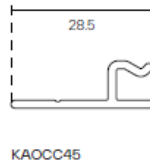

Figure 6 – Clip

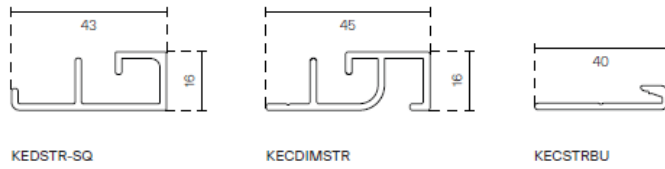

Figure 7 – Starters

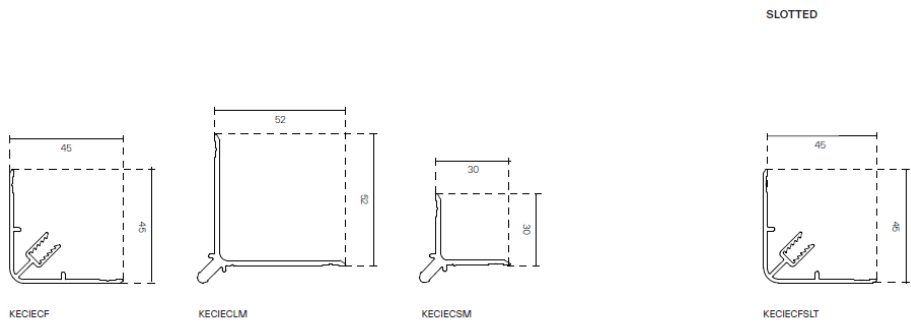

Figure 8 – Corner Trims

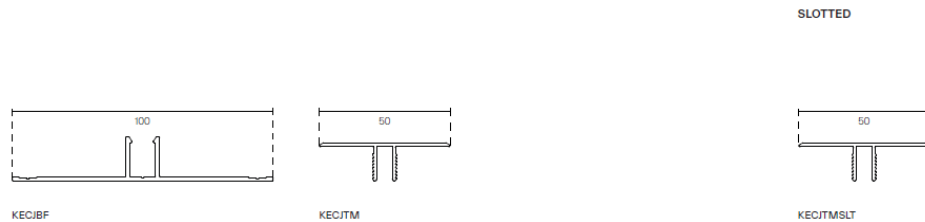

Figure 9 – Joiner Trims

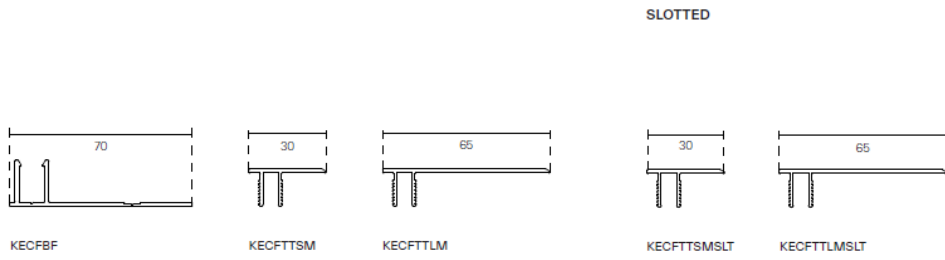

Figure 10 – End Trims

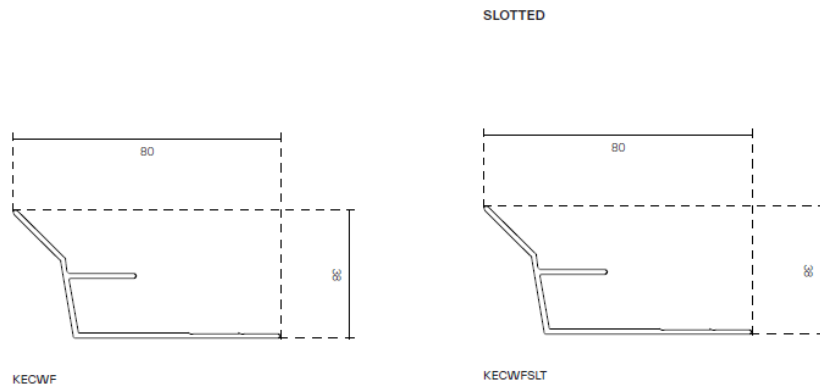

Figure 11 – Window Flashing

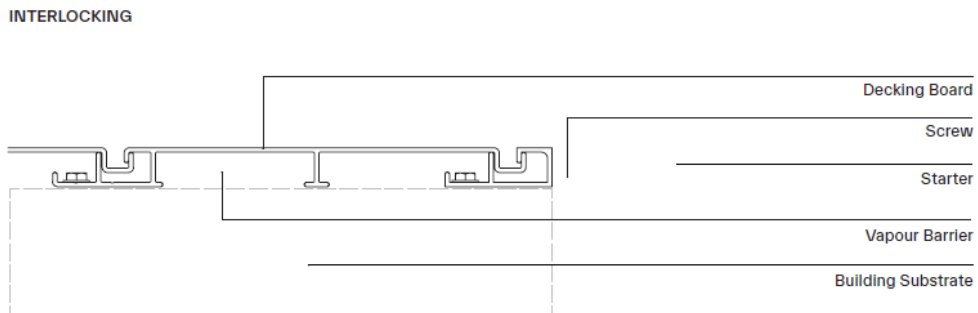

Figure 12 – Typical installation of Interlocking decking

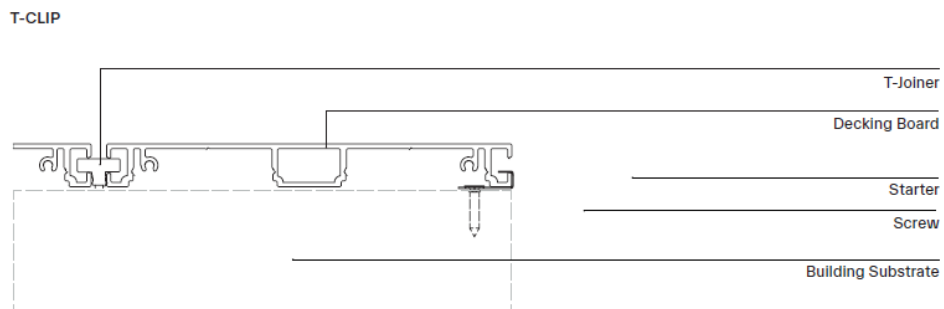
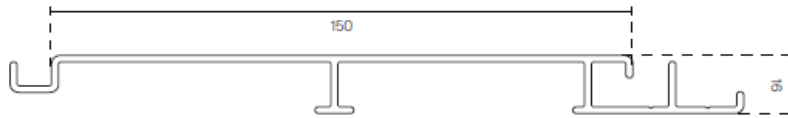
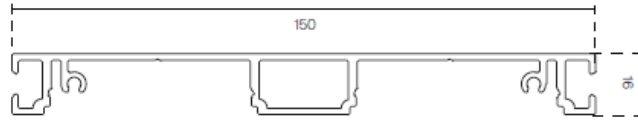

Figure 13 – Typical installation of T-Clip decking



KED150

Figure 14 – Interlocking Decking Board



KEDP150

Figure 15 – T-Clip Decking Board

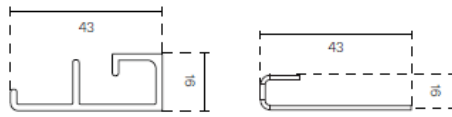

KESTR-SQ

KACLIPDSTART

Figure 16 – Starters

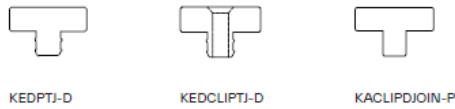

KEDPTJ-D

KEDCLIPTJ-D

KACLIPDJOIN-P

Figure 17 – T-Joiners

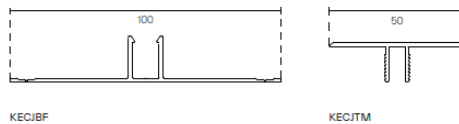

KECJBF

KECJTM

Figure 18 – Joiner Trims

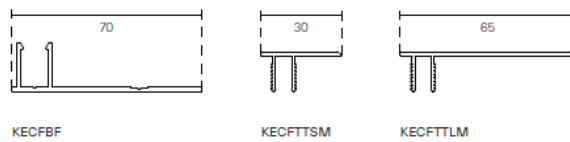

KECFBF

KECFTTSM

KECFTTLM

Figure 19 – End Trims

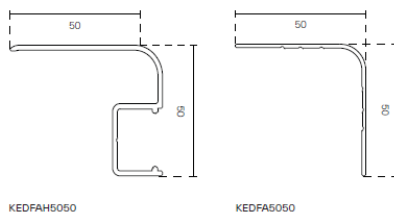

KEDFAH5050

KEDFA6050

Figure 20 – Finishing Pieces

4 Relevant requirements and evidence

4.1 AS 3959: 2018 “Non-combustible” definition

AS 3959: 2018 Amdt 1 or 1 & 2 Clause 1.5.23 defines **Non-combustible** as “not deemed combustible as determined by AS 1530.1 or not deemed combustible in accordance with the NCC.”

4.2 AS 3959: 2018 “Decking” definition

AS 3959: 2018 Amdt 1 or 1 & 2 Clause 1.5.9 defines **Decking** as “That part of the structure of verandas, decks, steps, ramps and landings that forms the trafficable surface of the structure.”

4.3 NCC 2019 Vol 1 C1.9 [NCC 2022 Vol 1 C2D10]

The relevant part of this clause is given below:

NCC 2019 Vol 1	NCC 2022 Vol 1	Governing Clauses
C1.9	C2D10	Non-combustible building elements
	5 (d)	The following materials, when entirely composed of itself, are non-combustible and may be used wherever a non-combustible material is required : <ul style="list-style-type: none"> - Aluminium, including aluminium alloy.
(e) (v)	(6) (e)	The following materials may be used wherever a non-combustible material is required : <ul style="list-style-type: none"> - Pre-finished metal sheeting having a combustible surface finish not exceeding 1 mm thickness and where the Spread-of-Flame Index of the product is not greater than 0.

4.4 NCC 2019 Vol 2 Part 3.7.1 [NCC 2022 Vol 2 H3D2]

The relevant part of this clause is given below:

NCC 2019 Vol 2	NCC 2022 Vol 2	Governing Clauses
Part 3.7.1 Fire properties for materials and construction	H3D2 Fire hazard properties and non-combustible building elements	
3.7.1.1 – General concession – non-combustible materials		
The following materials, though combustible or containing combustible fibres, may be used wherever a non-combustible material is required in the Housing Provisions :	(1) The following materials, though combustible or containing combustible fibres, may be used wherever a non-combustible material is required :	
(e)	(e)	Pre-finished metal sheeting having a combustible surface finish not exceeding 1 mm thick and where the Spread-of-Flame Index of the product is not more than 0.

4.5 NCC 2019 Vol 1 A5.5 [NCC 2022 Vol 1 A5G6]

The relevant part of this clause is given below:

NCC 2019 Vol 1	NCC 2022 Vol 1	Governing Clauses
A5.5	A5G6	Fire hazard properties
		Where a <i>Deemed-to-Satisfy Provision</i> requires a building component or assembly to have a <i>fire hazard property</i> it must be determined as follows:
(2)	(b)	... For <i>Smoke-Developed Index</i> and <i>Spread-of-Flame Index</i> , in accordance with Schedule 6. [Specification 3 – NCC 2022] ...

4.6 NCC 2019 Vol 1 Schedule 3 Definitions [NCC 2022 Vol 1 Definitions]

NCC 2019 Vol 1	NCC 2022 Vol 1	
Schedule 3 Definitions	Schedule 1 Definitions	
	Glossary	Fire hazard properties: The following properties of a material or assembly that indicate how they behave under specific fire test conditions: ... (b) <i>Smoke-Developed Index</i> , <i>smoke development rate</i> and <i>Spread-of-Flame Index</i> , determined in accordance with Schedule 6. [Specification 3 – NCC 2022] ...

4.7 NCC 2019 Vol 1 Schedule 6 [NCC 2022 Vol 1 Specification 3]

Schedule 6 [Specification 3] is titled “Fire Hazard Properties” however, it includes requirements for the determination of the “ability to screen its core material from free air”. The approach used in this report is to apply Schedule 6 [Specification 3] to the *Smoke-Developed Index* and *Spread-of-Flame Index* as defined in Schedule 3 Definitions [Schedule 1 Definitions] as being the “Fire Hazard Properties” of interest.

Based on this approach, the relevant parts of this schedule/specification as it applies to AS/NZS 1530.3 testing are the clauses below:

NCC 2019 Vol 1	NCC 2022 Vol 1
Schedule 6 – Fire Hazard Properties	Specification 3 – Fire Hazard Properties
1. Scope	S3C1 Scope
This Specification sets out the procedures for determining the fire hazard properties of assemblies tested to AS/NZS 1530.3.	This Schedule sets out the procedures for determining the fire hazard properties of assemblies tested to AS/NZS 1530.3.
2. Assemblies	Assemblies
2.1 General requirement	S3C2 General requirement
The fire hazard properties of assemblies and their ability to screen their core materials as required under Specification C1.10 must be determined by testing in accordance with this Clause.	The fire hazard properties of assemblies and their ability to screen their core materials as required under Specification 7 must be determined by testing in accordance with S3C3 to S3C6.
2.2 Form of test	S3C3 Form of test

NCC 2019 Vol 1	NCC 2022 Vol 1
Tests must be carried out in accordance with— (a) for the determination of the Spread-of-Flame Index and Smoke-Developed Index — AS/NZS 1530.3; and (b) for the determination of the ability to prevent ignition and to screen its core material from free air — AS 1530.4.	Tests must be carried out in accordance with— (a) for the determination of the Spread-of-Flame Index and Smoke-Developed Index — AS/NZS 1530.3; and (b) for the determination of the ability to prevent ignition and to screen its core material from free air — AS 1530.4.
2.3 Test specimens	S3C4 Test specimens
Test specimens must incorporate— (a) all types of joints; and (b) all types of perforations, recesses or the like for pipes, light switches or other fittings, which are proposed to be used for the member or assembly of members in the building.	Test specimens must incorporate— (a) all types of joints; and (b) all types of perforations, recesses or the like for pipes, light switches or other fittings, which are proposed to be used for the member or assembly of members in the building.
2.4 Concession	S3C5 Concession
Clause 2.3 does not apply to joints, perforations, recesses or the like that are larger than those in the proposed application and have already been tested in the particular form of construction concerned and found to comply with the conditions of the test.	S3C4 does not apply to joints, perforations, recesses or the like that are larger than those in the proposed application and have already been tested in the particular form of construction concerned and found to comply with the conditions of the test.

4.8 AS/NZS 1530.3-1999 Performance

Table 2 – Knotwood wall cladding products with Solid powder coat finish tested to AS/NZS 1530.3

Item No.	Test Report	Product	Colour tested	AS/NZS 1530.3 Indices (Ignitability, Spread of Flame, Heat Evolved, Smoke Developed)
1	AWTA-21-006332	Charisma solid flat matt colour range	black	0, 0, 0, 3
2	AWTA-21-006328	Duralloy Rapidcure range	white	14, 0, 0, 2
3	AWTA-20-006651	Duralloy solid colour range	black	15, 0, 0, 3
4	AWTA-20-006658	Duratec Elements textured range	black	14, 0, 0, 3
5	AWTA-21-006329	Duratec Intensity bright range	blue	13, 0, 0, 2
6	AWTA-21-006336	Duratec Zeus solid colour range	black	14, 0, 0, 3
7	AWTA-21-006330	Electro anodised look range	gold	13, 0, 0, 3
8	AWTA-21-006654	Fluorescent Allure pearlescent range	grey	17, 0, 0, 2
9	AWTA-20-006656	Fluoroset Xtreme solid colour range	grey	17, 0, 1, 1
10	AWTA-20-006659	Precious pearlescent range	grey	15, 0, 1, 2
11	AWTA-20-006657	Duratec Eternity pearlescent range	black	16, 0, 1, 2
12	AWTA-16-005953	D2525	white	12, 0, 0, 3

Item No.	Test Report	Product	Colour tested	AS/NZS 1530.3 Indices (Ignitability, Spread of Flame, Heat Evolved, Smoke Developed)
13	CSIRO FNE11423	Capral 1.6mm aluminium sheet powder coated with Interpon D1000	navy blue	0, 0, 0, 3

The AS/NZS 1530.3-1999 tests listed in Items 1 – 12 were conducted by the Australian Wool Testing Authority Ltd (AWTA) and were sponsored by Dulux Powder and Industrial Coatings with the exception of Item 12 which was sponsored by Akzo Nobel Pty Ltd. Item 13 was conducted by CSIRO and sponsored by Capral Limited. The respective sponsors of the tests have given permissions to Knotwood Pty Ltd to use the reports and to CSIRO to reference these reports in this advisory report.

Table 3 – Knotwood cladding products with sublimated timber grain finish tested to AS/NZS 1530.3

Item No.	Test Report	Product	Colour tested	AS/NZS 1530.3 Indices (Ignitability, Spread of Flame, Heat Evolved, Smoke Developed)
14	EWFA - 414179-01.1	Knotwood Timber Grain Finish (Kwila)	timber effect (brown)	0, 0, 0, 3
15	AWTA-23-004533	Knotwood Interlocking Aluminium Cladding with various sublimated timber grain finish	white beige brown black	10, 0, 0, 4

The AS/NZS 1530.3-1999 test conducted in Item 14 was conducted by Exova Warringtonfire sponsored by Knotwood Pty Ltd. Item 15 was conducted by AWTA and sponsored by Knotwood Pty Ltd.

Table 4 – Knotwood decking products with Slip-resistant timber grain finish tested to AS/NZS 1530.3

Item No.	Test Report	Product	Colour tested	AS/NZS 1530.3 Indices (Ignitability, Spread of Flame, Heat Evolved, Smoke Developed)
16	AWTA-23-004534	Knotwood Slip-Resistant Timber Grain Finish	white beige grey brown black	12, 0, 0, 2

The AS/NZS 1530.3-1999 test conducted in Item 16 was conducted AWTA and sponsored by Knotwood Pty Ltd.

4.9 Applicability of the referenced tests to a range of colours with respect to the Spread of Flame index

The tested powder-coated cladding and decking products listed in Tables 2, 3 and 4 are produced in a range of colours. AS/NZS 1530.3-1999 Clause 2.2.1 states: “Where a result for a range of colours of a material or component is required, at least two specimens of the lightest and darkest colours of the range shall be included in the first six specimens tested. If the variability of results exceeds that specified in Clause 2.8, additional specimens of the lightest and darkest shall be taken to determine the relevant indices for each colour.”

By reference to the test reports listed in Tables 2, 3 and 4, it is confirmed that all specimens tested covered the range of colours from the lightest to the darkest shades as required by the standard meeting the requirement of AS/NZS 1530.3-1999 Clause 2.2.1.

Of the four indices achieved from the AS/NZS 1530.3-1999 tests of specific interest is the Spread-of-Flame index which is the index required for the non-combustibility requirement. All the specimens tested and listed in Tables 2, 3 and 4 achieved the same Spread-of-Flame index, i.e. zero (0). This shows consistency across all the specimens that span the range of colours. It is therefore reasonable and conservative that a Spread-of-Flame index of zero (0) may be applied to the range of powder-coated aluminium sheet colours listed in Tables 2, 3 and 4.

4.10 Relevance of the requirements of NCC 2019 Vol 1 Schedule 6 [NCC 2022 Vol 1 Specification 3] and AS 3959: 2018 to the proposed construction

The proposed construction comprises Knotwood range of cladding and decking products in Table 1.

By observation of the proposed Knotwood range of cladding and decking products and components detailed in Section 3 and in reference to the tested products listed in Tables 2, 3 and 4, it is confirmed that the construction are made from pre-finished metal sheeting (aluminium alloy 6060) and have a combustible surface finish (powder-coating) not exceeding 1 mm thickness.

With reference to the discussion in Section 4.9, the *Spread-of-Flame Index* of zero (0) may be applied to the range of proposed construction.

With reference to AS 3959-2018 Amdt 1 or 1 & 2 Clause 1.5.23, **Non-combustible** is defined as “not deemed combustible as determined by AS 1530.1 or not deemed combustible in accordance with the NCC.”

As per Sections 4.3 of this report, NCC 2019 Vol 1 C1.9 (e)(v) and NCC 2022 Vol 1 C2D10 (6)(e) state that “pre-finished metal sheeting having a combustible surface finish not exceeding 1 mm thickness and where the Spread-of-Flame Index of the product is not more than 0” may be used wherever a non-combustible material is required.

As per Sections 4.5 and 4.6 of this report, the Spread-of-Flame Index shall be determined in accordance with Schedule 6 [Specification 3 – NCC 2022], which requires the material to be tested in accordance with AS/NZS 1530.3 with the requirements outlined in Clause 2.3/S3C4.

The AS/NZS 1530.3: 1999 tests listed in Tables 2, 3 and 4 were conducted on flat representative specimens with the paint finish coat exposed to the test. The specimens did not include any types of joints or any types of perforations, recesses or the like for pipes, light switches or other fittings, which are proposed to be used for the member or assembly of members in the building.

AS/NZS 1530.3: 1999 test was intended to determine the reaction to fire performance of the pre-painted metal sheeting product primarily for its paint finish coating when exposed to the radiant heat source. As the specimens are considered unlayered and homogeneous, and do not contain a core

material that may be shielded from fire exposure during the test nor does the assembly include any joints, perforations, recesses or the like, it is reasonable that the requirement of NCC 2019 Schedule 6 Clause 2.3 [NCC 2022 Specification 3 S3C4] for test specimens to incorporate all types of joints, perforations, recesses or the like, as outlined in Section 4.7 of this report, does not apply to the tested materials.

Based on the above, the proposed construction meets the requirement of NCC 2019 Vol 1 C1.9 (e)(v) and NCC 2022 Vol 1 C2D10 (6)(e) which state the tested materials may be used where the NCC requires non-combustible material.

With reference to AS 3959:2018 Amdt 1 or 1 & 2 Clause 1.5.23, materials that are deemed to be non-combustible in the NCC may be used where AS 3959:2018 Amdt 1 or 1 & 2 requires non-combustible materials installed.

*Powder coated aluminium used as **cladding**.*

With reference to AS 3959-2018 Amdt 1 or 1 & 2 Clauses 5.4.1 (c)(i) and 6.4.1 (c)(i) state:

The exposed components of an external wall that are less than 400 mm from the ground or less than 400 mm above decks, carport roofs, awnings and similar elements or fittings having an angle of less than 18 degrees to the horizontal and extending more than 110 mm in width from the wall (see Figure D3, Appendix D) shall be one of the following:

- (c) Cladding that is fixed externally to a timber-framed or a steel-framed wall and is—
 - (i) non-combustible material.

With reference to AS 3959:2018 Amdt 1 or 1 & 2 Clause 1.5.23, materials that are deemed to be non-combustible in the NCC may be used where AS 3959:2018 Amdt 1 or 1 & 2 requires non-combustible materials up to **BAL-19** for application as cladding as per the requirements of AS 3959-2018 Amdt 1 or 1 & 2 Clauses 5.4.1 (c)(i) and 6.4.1 (c)(i).

*Powder coated aluminium used as **decking**.*

With reference to AS 3959-2018 Amdt 1 or 1 & 2 Clauses 5.7.2.4 (a), 6.7.2.4 (a), 7.7.2.4 (a), 8.7.2.4 (a), state:

Decking, stair treads and the trafficable surfaces of ramps and landings less than 300 mm (measured horizontally at deck level) from glazed elements that are less than 400 mm (measured vertically) from the surface of the deck (see Figure D2, Appendix D) shall be made from—

- (a) non-combustible material;

With reference to AS 3959:2018 Amdt 1 or 1 & 2 Clauses 1.5.9 and 1.5.23, decking materials that are deemed to be non-combustible in the NCC may be used where AS 3959:2018 Amdt 1 or 1 & 2 requires non-combustible materials up to **BAL-40** for application as decking as per the requirements of AS 3959-2018 Amdt 1 or 1 & 2 Clauses 5.7.2.4 (a), 6.7.2.4 (a), 7.7.2.4 (a), 8.7.2.4 (a).

5 Conclusion

Based on a review of the construction specification in Section 3 and the relevant requirements and available data described in Section 4, it is confirmed that there is sufficient evidence for the determination of compliance for the proposed construction in Section 3 with the construction requirements of AS 3959: 2018 Amdt 1 or 1 & 2.

It is understood by CSIRO that the determination of compliance with the prescribed construction practices in AS 3959: 2018 Amdt 1 or 1 & 2 is to be undertaken by the Authority Having Jurisdiction.

Based on the above, a summary of the potential application for the cladding and decking materials considered in this report is listed in Table 5.

Table 5 – Summary of application for cladding and decking products.

Potential application in reference to the relevant AS 3959: 2018 clause	BAL 12.5	BAL 19	BAL 29	BAL 40
Knotwood Traditional and Dimensional cladding boards including components				
<p>The exposed components of an external wall that are less than 400 mm from the ground or less than 400 mm above decks, carport roofs, awnings and similar elements or fittings having an angle of less than 18 degrees to the horizontal and extending more than 110 mm in width from the wall (see Figure D3, Appendix D) shall be one of the following:</p> <p>(c) Cladding that is fixed externally to a timber-framed or a steel-framed wall and is—</p> <p style="padding-left: 40px;">(i) non-combustible material.</p>	<p>✓</p> <p>Clause 5.4.1 (c)(i)</p>	<p>✓</p> <p>Clause 6.4.1 (c)(i)</p>	n/a	n/a
Knotwood Interlocking and T-clip decking boards including components				
<p>Decking, stair treads and the trafficable surfaces of ramps and landings less than 300 mm (measured horizontally at deck level) from glazed elements that are less than 400 mm (measured vertically) from the surface of the deck (see Figure D2, Appendix D) shall be made from—</p> <p>(a) non-combustible material.</p>	<p>✓</p> <p>Clause 5.7.2.4 (a)</p>	<p>✓</p> <p>Clause 6.7.2.4 (a)</p>	<p>✓</p> <p>Clause 7.7.2.4 (a)</p>	<p>✓</p> <p>Clause 8.7.2.4 (a)</p>

6 Term of validity

This report will lapse on 28th February 2029. Should you wish us to re-examine this report with a view to the possible extension of its term of validity, please apply to us three to four months before the date of expiry. This Division reserves the right at any time to amend or withdraw this report in light of new knowledge.

7 Limitations

This report is prepared for the report client listed on page 1 and applies to the nominated materials and forms of construction in this report. Any modifications, changes or amendments to the referenced standards or regulations may invalidate the findings of this report.

Appendix A Supporting Test Data

A.1 AWTA Test Report No. 21-006332

AWTA Test Report No. 21-006332, issued on 5th of January 2022 by AWTA, details the test results for Charisma solid flat matt colour range when tested in accordance with AS/NZS 1530.3: 1999. Nine specimens were tested in accordance with AS/NZS 1530.3: 1999. Table 6 presents the summary of the results.

Date of Test: 5 January 2022

Test Sponsor: Dulux Powder and Industrial Coatings

Manufacturer: Dulux Powder and Industrial Coatings

The test sponsor described the tested specimen as a polyester powder coating applied to aluminium panel.

Nominal thickness of aluminium panel: 1 mm

Colour (exposed face): black

Table 6 – Summary of results

For regulatory purposes these figures correspond to the following indices:

Ignitability Index (0-20)	Spread of Flame Index (0-10)	Heat Evolved Index (0-10)	Smoke Developed Index (0-10)
0	0	0	3

A.2 AWTA Test Report No. 21-006328

AWTA Test Report No. 21-006328, issued on 22nd of December 2021 by AWTA, details the test results for Duralloy Rapidcure colour range when tested in accordance with AS/NZS 1530.3: 1999. Six specimens were tested in accordance with AS/NZS 1530.3: 1999. Table 7 presents the summary of the results.

Date of Test: 22 December 2021

Test Sponsor: Dulux Powder and Industrial Coatings

Manufacturer: Dulux Powder and Industrial Coatings

The test sponsor described the tested specimen as a polyester powder coating applied to aluminium panel.

Nominal thickness of aluminium panel: 1 mm

Colour (exposed face): white

Table 7 – Summary of results

For regulatory purposes these figures correspond to the following indices:

Ignitability Index (0-20)	Spread of Flame Index (0-10)	Heat Evolved Index (0-10)	Smoke Developed Index (0-10)
14	0	0	2

A.3 AWTA Test Report No. 20-006651

AWTA Test Report No. 21-006651, issued on 11th of January 2021 by AWTA, details the test results for Duralloy solid colour range when tested in accordance with AS/NZS 1530.3: 1999. Nine specimens were tested in accordance with AS/NZS 1530.3: 1999. Table 8 presents the summary of the results.

Date of Test: 11 January 2021

Test Sponsor: Dulux Powder and Industrial Coatings

Manufacturer: Dulux Powder and Industrial Coatings

The test sponsor described the tested specimen as a polyester powder coating applied to aluminium panel.

Nominal thickness of aluminium panel: 1 mm

Colour (exposed face): black

Table 8 – Summary of results

For regulatory purposes these figures correspond to the following indices:

Ignitability Index (0-20)	Spread of Flame Index (0-10)	Heat Evolved Index (0-10)	Smoke Developed Index (0-10)
15	0	0	3

A.4 AWTA Test Report No. 20-006658

AWTA Test Report No. 21-006658, issued on 13th of January 2021 by AWTA, details the test results for Duratec Elements textured range when tested in accordance with AS/NZS 1530.3: 1999. Nine specimens were tested in accordance with AS/NZS 1530.3: 1999. Table 9 presents the summary of the results.

Date of Test: 13 January 2021

Test Sponsor: Dulux Powder and Industrial Coatings

Manufacturer: Dulux Powder and Industrial Coatings

The test sponsor described the tested specimen as a polyester powder coating applied to aluminium panel.

Nominal thickness of aluminium panel: 1 mm

Colour (exposed face): black

Table 9 – Summary of results

For regulatory purposes these figures correspond to the following indices:

Ignitability Index (0-20)	Spread of Flame Index (0-10)	Heat Evolved Index (0-10)	Smoke Developed Index (0-10)
14	0	0	3

A.5 AWTA Test Report No. 21-006329

AWTA Test Report No. 21-006329, issued on 4th of January 2022 by AWTA, details the test results for Duratec Intensity bright range when tested in accordance with AS/NZS 1530.3: 1999. Nine specimens were tested in accordance with AS/NZS 1530.3: 1999. Table 10 presents the summary of the results.

Date of Test: 4 January 2022

Test Sponsor: Dulux Powder and Industrial Coatings

Manufacturer: Dulux Powder and Industrial Coatings

The test sponsor described the tested specimen as a polyester powder coating applied to aluminium panel.

Nominal thickness of aluminium panel: 1 mm

Colour (exposed face): blue

Table 10 – Summary of results

For regulatory purposes these figures correspond to the following indices:

Ignitability Index (0-20)	Spread of Flame Index (0-10)	Heat Evolved Index (0-10)	Smoke Developed Index (0-10)
13	0	0	2

A.6 AWTA Test Report No. 21-006336

AWTA Test Report No. 21-006336, issued on 6th of January 2022 by AWTA, details the test results for Duratec Zeus solid colour range when tested in accordance with AS/NZS 1530.3: 1999. Nine specimens were tested in accordance with AS/NZS 1530.3: 1999. Table 11 presents the summary of the results.

Date of Test: 6 January 2022

Test Sponsor: Dulux Powder and Industrial Coatings

Manufacturer: Dulux Powder and Industrial Coatings

The test sponsor described the tested specimen as a polyester powder coating applied to aluminium panel.

Nominal thickness of aluminium panel: 1 mm

Colour (exposed face): black

Table 11 – Summary of results

For regulatory purposes these figures correspond to the following indices:

Ignitability Index (0-20)	Spread of Flame Index (0-10)	Heat Evolved Index (0-10)	Smoke Developed Index (0-10)
14	0	0	3

A.7 AWTA Test Report No. 21-006330

AWTA Test Report No. 21-006336, issued on 4th of January 2022 by AWTA, details the test results for Electro anodised look range when tested in accordance with AS/NZS 1530.3: 1999. Nine specimens were tested in accordance with AS/NZS 1530.3: 1999. Table 12 presents the summary of the results.

Date of Test: 4 January 2022

Test Sponsor: Dulux Powder and Industrial Coatings

Manufacturer: Dulux Powder and Industrial Coatings

The test sponsor described the tested specimen as a polyester powder coating applied to aluminium panel.

Nominal thickness of aluminium panel: 1 mm

Colour (exposed face): gold

Table 12 – Summary of results

For regulatory purposes these figures correspond to the following indices:

Ignitability Index (0-20)	Spread of Flame Index (0-10)	Heat Evolved Index (0-10)	Smoke Developed Index (0-10)
13	0	0	3

A.8 AWTA Test Report No. 20-006654

AWTA Test Report No. 20-006654, issued on 12th of January 2021 by AWTA, details the test results for Fluorescent Allure pearlescent range when tested in accordance with AS/NZS 1530.3: 1999. Six specimens were tested in accordance with AS/NZS 1530.3: 1999. Table 13 presents the summary of the results.

Date of Test: 12 January 2021

Test Sponsor: Dulux Powder and Industrial Coatings

Manufacturer: Dulux Powder and Industrial Coatings

The test sponsor described the tested specimen as a fluoropolymer powder coating applied to aluminium panel.

Nominal thickness of aluminium panel: 1 mm

Colour (exposed face): grey

Table 13 – Summary of results

For regulatory purposes these figures correspond to the following indices:

Ignitability Index (0-20)	Spread of Flame Index (0-10)	Heat Evolved Index (0-10)	Smoke Developed Index (0-10)
17	0	0	2

A.9 AWTA Test Report No. 20-006656

AWTA Test Report No. 20-006656, issued on 12th of January 2021 by AWTA, details the test results for Fluoroset Xtreme solid colour range when tested in accordance with AS/NZS 1530.3: 1999. Six specimens were tested in accordance with AS/NZS 1530.3: 1999. Table 14 presents the summary of the results.

Date of Test: 12 January 2021

Test Sponsor: Dulux Powder and Industrial Coatings

Manufacturer: Dulux Powder and Industrial Coatings

The test sponsor described the tested specimen as a fluoropolymer powder coating applied to aluminium panel.

Nominal thickness of aluminium panel: 1 mm

Colour (exposed face): grey

Table 14 – Summary of results

For regulatory purposes these figures correspond to the following indices:

Ignitability Index (0-20)	Spread of Flame Index (0-10)	Heat Evolved Index (0-10)	Smoke Developed Index (0-10)
17	0	1	1

A.10 AWTA Test Report No. 20-006659

AWTA Test Report No. 20-006659, issued on 13th of January 2021 by AWTA, details the test results for Precious pearlescent range when tested in accordance with AS/NZS 1530.3: 1999. Six specimens were tested in accordance with AS/NZS 1530.3: 1999. Table 15 presents the summary of the results.

Date of Test: 13 January 2021

Test Sponsor: Dulux Powder and Industrial Coatings

Manufacturer: Dulux Powder and Industrial Coatings

The test sponsor described the tested specimen as a polyester powder coating applied to aluminium panel.

Nominal thickness of aluminium panel: 1 mm

Colour (exposed face): grey

Table 15 – Summary of results

For regulatory purposes these figures correspond to the following indices:

Ignitability Index (0-20)	Spread of Flame Index (0-10)	Heat Evolved Index (0-10)	Smoke Developed Index (0-10)
15	0	1	2

A.11 AWTA Test Report No. 20-006657

AWTA Test Report No. 20-006657, issued on 12th of January 2021 by AWTA, details the test results for Duratec Eternity pearlescent range when tested in accordance with AS/NZS 1530.3: 1999. Six specimens were tested in accordance with AS/NZS 1530.3: 1999. Table 16 presents the summary of the results.

Date of Test: 12 January 2021

Test Sponsor: Dulux Powder and Industrial Coatings

Manufacturer: Dulux Powder and Industrial Coatings

The test sponsor described the tested specimen as a polyester powder coating applied to aluminium panel.

Nominal thickness of aluminium panel: 1 mm

Colour (exposed face): black

Table 16 – Summary of results

For regulatory purposes these figures correspond to the following indices:

Ignitability Index (0-20)	Spread of Flame Index (0-10)	Heat Evolved Index (0-10)	Smoke Developed Index (0-10)
16	0	1	2

A.12 AWTA Test Report No. 16-005953

AWTA Test Report No. 16-005953, issued on 5th of December 2016 by AWTA, details the test results for D2525 when tested in accordance with AS/NZS 1530.3: 1999. Six specimens were tested in accordance with AS/NZS 1530.3: 1999. Table 17 presents the summary of the results.

Date of Test: 12 January 2021

Test Sponsor: Akzo Nobel Pty Ltd

Manufacturer: not provided

The test sponsor described the tested specimen as a polyester powder coating applied to aluminium panel.

Nominal thickness of aluminium panel: 1 mm

Colour (exposed face): white

Table 17 – Summary of results

For regulatory purposes these figures correspond to the following indices:

Ignitability Index (0-20)	Spread of Flame Index (0-10)	Heat Evolved Index (0-10)	Smoke Developed Index (0-10)
12	0	0	3

A.13 CSIRO Test Report No. FNE11423

CSIRO Test Report No. FNE11423, issued on 3rd of July 2015 by CSIRO, details the test results for Capral 1.6mm Aluminium Sheet powder coated with Interpon D1000 powder coat when tested in accordance with AS/NZS 1530.3: 1999. Six specimens were tested in accordance with AS/NZS 1530.3: 1999. Table 18 presents the summary of the results.

Date of Test: 22 June 2015
Test Sponsor: Capral Ltd
Manufacturer: not provided

The test sponsor described the tested specimen as a 1.6mm thick 5005 aluminium sheet powder coated with Interpon D1000 powder coat.

Nominal thickness of aluminium panel: 1.6 mm
Colour (exposed face): dark navy blue

Table 18 – Summary of results

For regulatory purposes these figures correspond to the following indices:

Ignitability Index (0-20)	Spread of Flame Index (0-10)	Heat Evolved Index (0-10)	Smoke Developed Index (0-10)
0	0	0	3

A.14 Exova Warringtonfire Aus Pty Ltd Test Report No. 414179-01.1

Exova Warringtonfire Aus Pty Ltd Test Report No. 414179-01.1, issued on 30th of March 2016 by Exova Warringtonfire Aus Pty Ltd, details the test results for Aluminium panels painted with timber effect when tested in accordance with AS/NZS 1530.3: 1999. Six specimens were tested in accordance with AS/NZS 1530.3: 1999. Table 19 presents the summary of the results.

Date of Test: 29 March 2016
Test Sponsor: Knotwood Pty Ltd
Manufacturer: not provided

The test sponsor described the tested specimen as a 19 mm thick aluminium sheet painted with a timber effect.

Nominal thickness of aluminium panel: 19 mm
Colour (exposed face): timber effect

Table 19 – Summary of results

For regulatory purposes these figures correspond to the following indices:

Ignitability Index (0-20)	Spread of Flame Index (0-10)	Heat Evolved Index (0-10)	Smoke Developed Index (0-10)
0	0	0	3

A.15 AWTA Test Report No. 23-004533

AWTA Test Report No. 23-004533, issued on 18th of December 2023 by AWTA, details the test results for Knotwood Interlocking Aluminium Cladding when tested in accordance with AS/NZS 1530.3: 1999. Nine specimens were tested in accordance with AS/NZS 1530.3: 1999. Table 20 presents the summary of the results.

Date of Test: 15 December 2023
Test Sponsor: Knotwood Pty Ltd
Manufacturer: not provided

The test sponsor described the tested specimen as aluminium with sublimated, powder coat finish.
Nominal thickness of aluminium panel: 1.8 mm
Colour (exposed face): various (lightest to darkest shades)

Table 20 – Summary of results

For regulatory purposes these figures correspond to the following indices:

Ignitability Index (0-20)	Spread of Flame Index (0-10)	Heat Evolved Index (0-10)	Smoke Developed Index (0-10)
10	0	0	4

A.16 AWTA Test Report No. 23-004534

AWTA Test Report No. 23-004534, issued on 19th of December 2023 by AWTA, details the test results for Knotwood Slip Resistant Decking when tested in accordance with AS/NZS 1530.3: 1999. Six specimens were tested in accordance with AS/NZS 1530.3: 1999. Table 21 presents the summary of the results.

Date of Test: 15 December 2023
Test Sponsor: Knotwood Pty Ltd
Manufacturer: not provided

The test sponsor described the tested specimen as aluminium with sublimated, slip-resistant powder coat finish.
Nominal thickness of aluminium panel: 1.8 mm
Colour (exposed face): various (lightest to darkest shades)

Table 21 – Summary of results

For regulatory purposes these figures correspond to the following indices:

Ignitability Index (0-20)	Spread of Flame Index (0-10)	Heat Evolved Index (0-10)	Smoke Developed Index (0-10)
12	0	0	2

CONTACT US

t 1300 363 400
+61 3 9252 6000
e enquiries@csiro.au
w www.csiro.au

YOUR CSIRO

Australia is founding its future in science and innovation. Its national science agency, CSIRO, is a powerhouse of ideas, technologies and skills for building prosperity, growth, health and sustainability. It serves governments, industries, business and communities across the nation.

FOR FURTHER INFORMATION

Infrastructure Technologies

Keith Nicholls
Group Leader – Fire Testing and Assessments
t +61 2 9490 5450
e keith.nicholls@csiro.au
w <https://research.csiro.au/infratech/fire-safety/fire-testing/>

Infrastructure Technologies

Heherson Alarde
Fire Assessments Engineer
t +61 2 9325 3033
e heherson.alarde@csiro.au
w <https://research.csiro.au/infratech/fire-safety/fire-testing/>